

HD Video Conferencing Camera

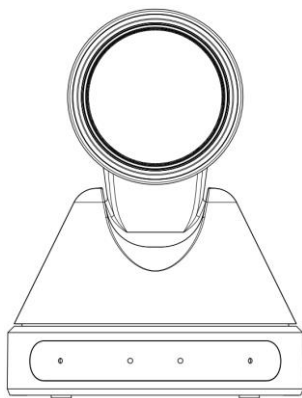

User Manual

V1.0

(English)

Preface

Thanks for using this HD Video Conferencing Camera.

This manual introduces the functions, installation process and operation of the HD camera. Prior to installation and usage, please read the manual thoroughly.

Precautions

This product can only be used in the specified conditions in order to avoid any damage to the camera:

- Don't subject the camera to rain or moisture.
- Don't remove the cover. Otherwise, you may get an electric shock. In case of abnormal operation of equipment, contact the authorized engineer.
- Never operate under unspecified temperature, humidity or power supply.
- Please use soft dry cloth to clean the camera. If the camera is very dirty, clean it with diluted neuter detergent; do not use any type of solvents, which may damage the surface.

Note:

This is class A production. Electromagnetic radiation at specific frequencies may affect the image quality of TV in home environment.

Copyright Notice

All contents of this manual, whose copyright belongs to our Corporation cannot be cloned, copied or translated without the permission of the company. Product specifications and information which were referred to in this document are for reference only. We may change, delete, or update any content at any time and without prior notice.

Contents

Note.....	4
Supplied Accessories.....	4
Quick Start	5
Features	6
Main Unit.....	9
Size.....	10
IR Remote Control Explanation	11
RS-232 Interface	13
Serial Communication Control.....	14
PTZ over TCP/UDP	14
Command List.....	14
Menu Setting.....	15
Network Function.....	20
Maintenance and Troubleshooting.....	29

Note

- **Electric Safety**

Installation and operation must accord with electric safety standard.

- **Use caution to transport**

Avoid stress, vibration or soakage in transport, storage and installation.

- **Polarity of power supply**

The power supply of this product is +12V, the max electrical current is 2A .Polarity of the power supply plug drawing shows as below.



- **Installation Precautions**

Do not grasp the camera lens when carrying it. Don't touch camera lens by hand. Mechanical damage may be caused by doing so.

Do not use in corrosive liquid, gas or solid environment to avoid any cover (plastic material) damage.

Make sure there is no obstacle within rotation range.

Never power on before installation is completed.

- **Do not dismantle the camera**

We are not responsible for any unauthorized modification or dismantling.

CAUTION!

Specific frequencies of electromagnetic field may affect the image of the camera!

Supplied Accessories

When unpacked, check if all supplied accessories are included:

Camera	1PCS
AC power adaptor	1PCS
Power cord.....	1PCS
RS232 cable.....	1PCS
Remote control.....	1PCS
User manual.....	1PCS

Quick Start

Step1. Check if connections are correct before starting

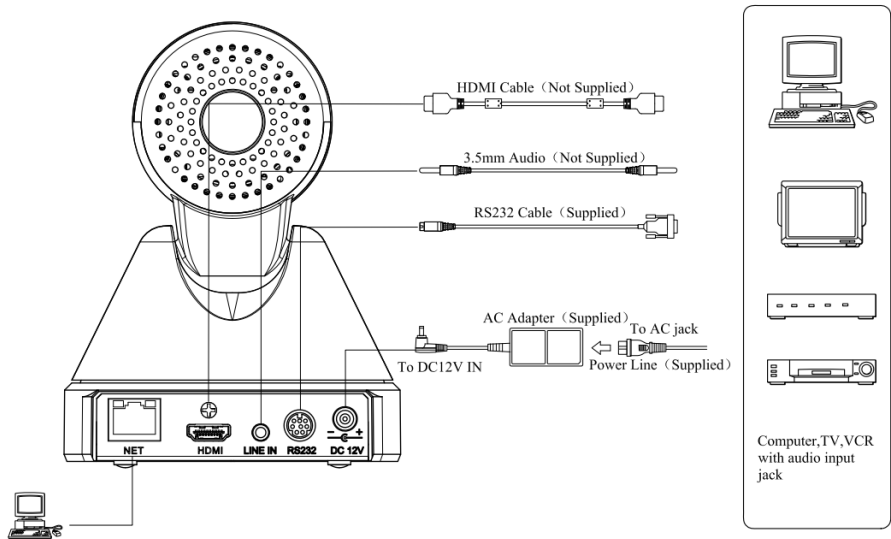

Step2. Press the ON/OFF switch on the right rear of the camera, power light on.

Step3. Pan-Tilt function rotates the camera to its maximum position of top right upon startup, then it returns to the center, and the process of initialization is finished. (Note: if there is an entry for position preset 0, the corresponding position preset 0 will be called up after initialization.)

Features

- **Completely New Look**

Designed with worm gear transmission, completely new look, mini size.

- **1080P Full HD**

Support Panasonic's 1/2.7 inch, 2.07 million effective pixels with high quality HD CMOS sensor. The camera can reach a maximum of 1920 x 1080 high resolution and achieve high-quality image.

- **Ultra-high Frame Rate**

The output frame rate can be up to 60fps in 1080P.

- **72.5° Wide-angle Lens + 16x Digital Zoom**

Use 72.5° wide-angle high quality lens, support 12x optical zoom, and 16x digital zoom.

- **AAC Audio Encoding**

Support AAC audio encoding, better sound quality and smaller bandwidth.

- **Low-light**

High SNR of CMOS sensor combined with 2D and 3D noise reduction algorithm, effectively reduce the noise. Even under low illumination conditions, clear images can still be acquired.

- **72.5° Wide-angle Lens+ 16x Digital Zoom**

Use 72.5° wide-angle high quality lens, supporting 12x optical zoom and 32x digital zoom.

- **Remote Control**

Use RS232/485 interface. All parameters of the camera can be remotely controlled by the high-speed communication.

Product Specification

Name	HD Video Conferencing Camera
Camera	
Video System	HD: 1080p/60, 1080p/50, 1080i/60, 1080i/50, 1080p/30, 1080p/25, 720p/60, 720p/50, 720p30, 720p25
Sensor	1/2.7", CMOS, Effective Pixel: 2.07M
Scanning Mode	Progressive
Lens	12x, f3.5mm ~ 42.3mm, F1.8 ~ F2.8
Digital Zoom	16x
Minimal Illumination	0.5 Lux @ (F1.8, AGC ON)
Shutter	1/30s ~ 1/10000s
White Balance	Auto, Indoor, Outdoor, One Push, Manual
Backlight Compensation	Support
Digital Noise Reduction	2D&3D Digital Noise Reduction
Video S/N	≥55dB
Horizontal Angle of View	72.5° ~ 6.9°
Vertical Angle of View	44.8° ~ 3.9°
Horizontal Rotation Range	±170°
Vertical Rotation Range	-30° ~ +30°
Pan Speed Range	1.7° ~ 100°/s
Tilt Speed Range	0.7° ~ 28°/s
H & V flip	Support
Image Freeze	Support
Number of Preset	255
Preset Accuracy	0.1°
IPC Features	
Video coding standard	H.265/H.264/MJPEG
Video Stream	First stream, Second stream

First stream resolution	1920x1080,1280x720,1024x576,960x540,640x480,640x360
Second stream resolution	1280x720,1024x576,720x576(50Hz Under),720x480(60Hz Under),720x408,640x360,480x270,320x240,320x180
Video Bit Rate	32Kbps ~ 20480Kbps
Bit Rate Type	Variable rate, Fixed rate
Frame Rate	1fps ~ 30fps
Audio encode standard	AAC
Audio stream rate	96Kbps, 128Kbps, 256Kbps
Support protocols	TCP/IP, HTTP, RTSP, RTMP, ONVIF, DHCP, Multicast, etc.
Input/Output Interface	
HD Output	1xHDMI: Version 1.3
Network interface	1xRJ45: 10M/100M Ethernet Interface
Audio Interface	1-ch 3.5mm audio interface, Line In
Communication interface	1xRS-232 : 8pin Min DIN, Max Distance: 30m, Protocol: VISCA/Pelco-D/ Pelco-P
Power jack	JEITA type (DC IN 12V)
Generic Specification	
Input Voltage	DC 12V
Current Consumption	1.0A (Max)
Operating Temperature	-10°C ~ 40°C (14°F ~ 104°F)
Storage Temperature	-40°C ~ 60°C (-40°F ~ 140°F)
Power Consumption	12W (Max)
MTBF	>30000h
Size	128.5mm x 118.0mm x 156.2mm
Net Weight	0.9K g

Main Unit

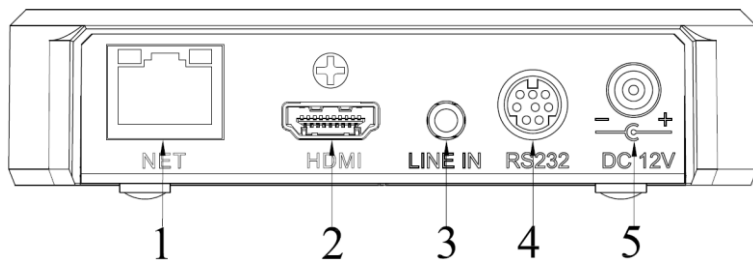

1. RJ45 interface

2. HDMI interface

5. DC IN 12V interface

3. LINE IN interface

4. RS232 interface

Size

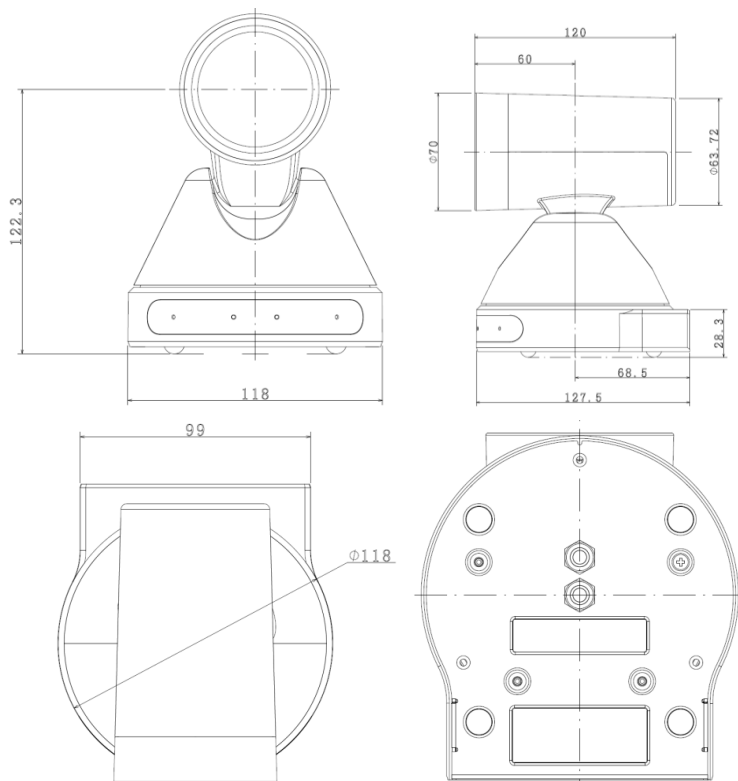

IR Remote Control Explanation

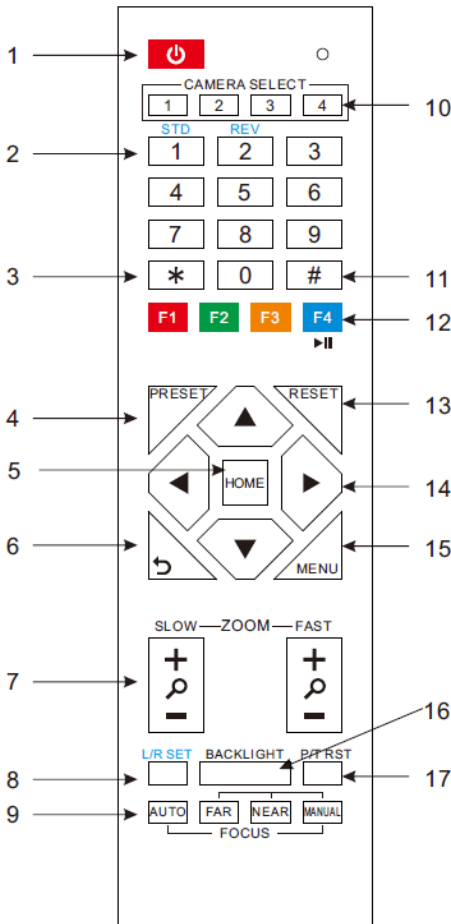

1. Standby Button

Press this button to enter standby mode.
Press it again to enter normal mode. (Note: Power consumption in standby mode is approximately half of the normal mode).

2. Position Buttons

To set or call preset.

3. *Button

Use with other buttons.

4. Set/ Preset Buttons

Set/ preset: store a preset position.
[SET/ PRESET] + Numeric button (0-9): set a corresponding numeric key for the preset position.

5. Pan-Tilt control Buttons

Press the Pan-Tilt buttons to move back to the middle position

6. Back buttons

Press the OSD menu to return to the previous page.

7. Zoom Buttons

Slow Zoom: Zoom In [+] or Zoom Out [-] slowly.

Fast Zoom: Zoom In [+] or Zoom Out [-] fast.

8. Pan-Tilt L/R set

Press 1 and 2 buttons to set the direction of the Pan-Tilt.

L/R Set +1[STD]: set the Pan-Tilt turn the same direction as the L/R Set.

L/R Set +2[REV]: set the Pan-Tilt turn the opposite direction to the L/R Set.

9. Focus Buttons

Use for focus adjustment.

Press [AUTO] to adjust the focus on the center of the object automatically. To adjust the focus manually, press [MANUAL]. Adjust focus with [Far] (focus on far object) or [NEAR] (focus on near object).

10. Camera Select Buttons

Press the button corresponding to the camera being operated with the remote control.

11. # Button

Use with other buttons.

12. Camera IR Address Setup Buttons

[*]+[#]+[F1]: Address1

[*]+[#]+[F2]: Address2

[*]+[#]+[F3]: Address3

[*]+[#]+[F4]: Address4

13. Clear Preset Buttons

Clear preset: erase a preset position.

[CLEAR PRESET] + Numeric button (0-9) individually.

Or: [*]+[#]+[CLEAR PRESET]: erase all the preset positions.

14. Pan/Tilt Control Buttons

Press arrow buttons to perform panning and tilting.

Press [HOME] to reposition the camera back to front.

15. MENU

MENU: enter or exit OSD MENU.

16. BLC (Backlight Compensation) Button

BLC ON/OFF: Press this button to enable the backlight compensation. Press it again to disable the backlight compensation. (NOTE: effective

only in auto exposure mode).

Note: if there is light source behind the subject, the subject will become dark. In this case, press the backlight ON/OFF button to adjust.

17. Pan/Tilt reset

Preset Pan/Tilt self-test.

18. Image freezing function

Manually freeze: Enable the freezing function after pressing [F4] on the remote control. Display "Freeze" on the upper left corner of the screen, and disappear automatically after 5 seconds. Press [F4] again to return to normal mode. Display "Unfreeze" on the upper left corner of the screen, and disappear automatically after 5 seconds.

Recall the Preset image Freeze: use "Recalling the Preset image Freeze" function in the OSD Menu. After the function is activated, the screen pauses, and can be switched to any preset position by pressing the corresponding number.

19. Shortcut Setup

[*]+[#]+[1]: OSD menu default English

[*]+[#]+[3]: OSD menu default Chinese

[*]+[#]+[4]: Default IP address

[*]+[#]+[5]: Save OSD

[*]+[#]+[6]: Quick default reset

[*]+[#]+[8]: Look up camera version

[*]+[#]+[9]: Quick inversion setup

RS-232 Interface

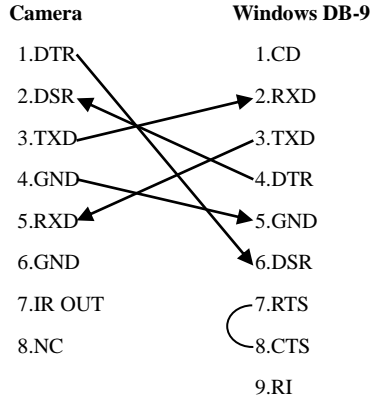
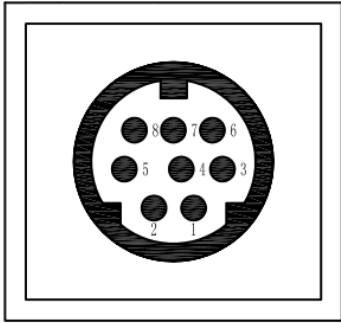

No.	Function
1	DTR
2	DSR
3	TXD
4	GND
5	RXD
6	GND
7	IR OUT
8	NC

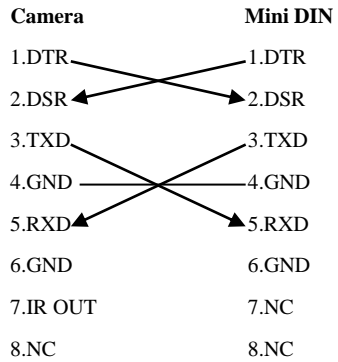

Serial Communication Control

In default working mode, the camera is able to connect to a VISCA controller with RS232C serial interface.

➤ **RS232 Communication Control:**

The camera can be controlled via RS232. The parameters of RS232C are as follows:

Bit rate: 2400/4800/9600/38400 bit/s.

Start bit: 1 bit.

Data bit: 8 bits.

Stop bit: 1bit.

Parity bit: none.

Pan-Tilt function rotates the camera to its maximum position of top right upon startup, then it returns to the center, and the process of initialization is finished. (Note: if there is an entry for position preset 0, the corresponding position preset 0 will be called up after initialization.) Then user can control the camera with commands in the command list.

PTZ over TCP/UDP

A TCP server is embedded in camera, port number 5678. When the user establishes a TCP connection with the server, and sends a PTZ control command to the server, the server will parse and execute the PTZ command.

A UDP server is embedded in camera, port number 1259. When the user sends a PTZ control command, the server will parse and execute the PTZ command.

Command List

Ignore

Note:

The camera serial standard VISCA/Pelco-D/Pelco-P needs secondary development. If VISCA/Pelco - D/Pelco - P protocol command is needed, please list in detail and contact the manufacturer.

Menu Setting

1. MENU

Press [MENU] to display the main menu on the screen. Use arrow buttons to move the cursor. Press [HOME] to enter the corresponding sub-menu.

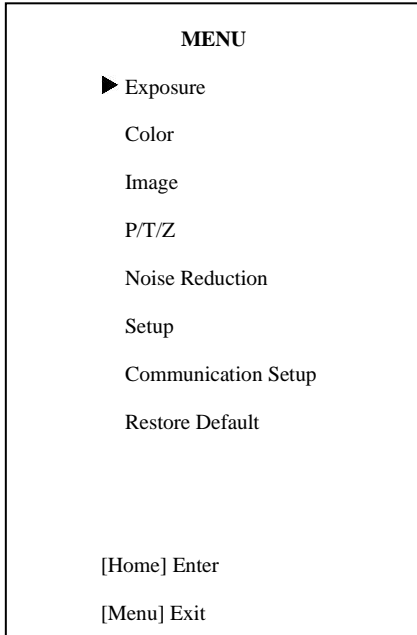

2. EXPOSURE

Move the cursor to the Exposure in the main menu and press [HOME], EXPOSURE menu shows as below.

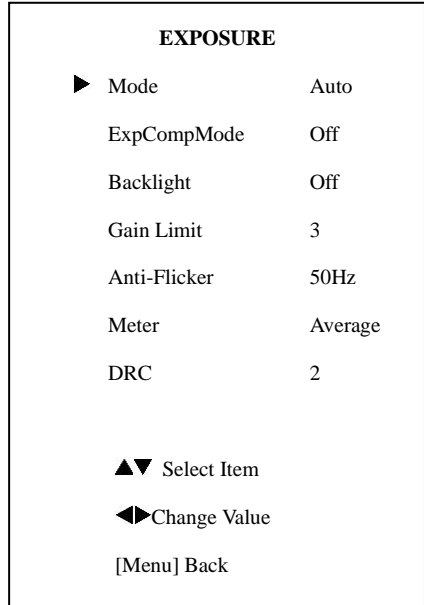

Mode: Exposure mode. Options: Auto, Manual, SAE, AAE, Bright.

ExpCompMode: Exposure compensation mode. Options: On, Off (Effective only in Auto mode).

ExpComp: Exposure compensation value. Options: -7 ~ 7(Effective only when ExpCompMode is On)

Backlight: Set the backlight compensation. Options: On, Off (Effective only in Auto mode)

Bright: Bright intensity control. Options: 00~17. (Effective only in Bright mode)

Gain Limit: Maximum gain. Options: 0 ~ 15 (Effective only in Auto, AAE, Bright mode)

Anti-Flicker: Options: Off, 50Hz, 60Hz (Effective only in Auto, Bright mode)

Meter: Options: Average, Center, Bottom,

Top

Iris: Aperture value. Options: F1.8, F2.0, F2.4, F2.8, F3.4, F4.0, F4.8, F5.6, F6.8, F8.0, F9.6, F11.0, Close (Effective only in Manual, AAE mode)

Shut: Shutter value. Options: 1/30, 1/60, 1/90, 1/100, 1/125, 1/180, 1/250, 1/350, 1/500, 1/725, 1/1000, 1/1500, 1/2000, 1/3000, 1/4000, 1/6000, 1/10000 (Effective only in Manual, SAE mode)

DRC: DRC strength. Options: 0 ~ 8.

RG: Red gain. Options: 0~255 (Effective only in Manual mode)

BG: Blue gain. Options: 0~255 (Effective only in Manual mode)

RG Tuning: Red gain fine-tuning. Options: -10 ~ +10 (Effective only when AWBsens is Low)

BG Tuning: Blue gain fine-tuning. Options: -10 ~ +10 (Effective only when AWBsens is Low)

Saturation: Options: 60% ~ 200%.

Hue: Chroma adjustment. Options: 0 ~ 14.

AWBsens: White balance sensitivity. Options: Normal, High, Low.

3. COLOR

Move the cursor to the Color in the main menu and press [HOME], COLOR menu shows as below.

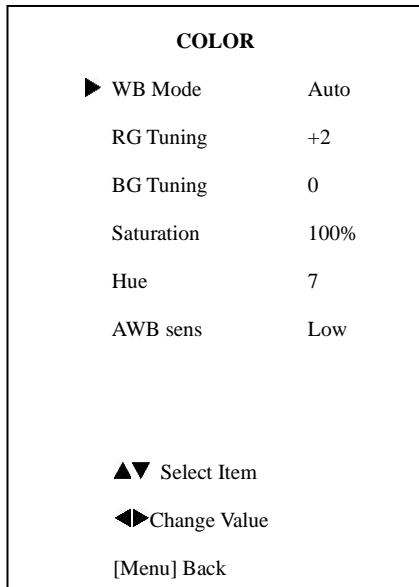

WB Mode: White balance mode. Options: Auto, Indoor, Outdoor, One Push, Manual.

4. IMAGE

Move the cursor to the Image in the main menu and press [HOME], IMAGE menu shows as below.

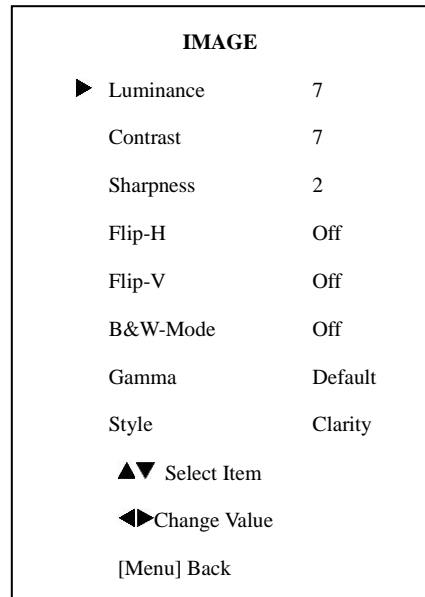

Luminance: Brightness adjustment. Options: 0~14

Contrast: Contrast adjustment. Options: 0~14

Sharpness: Sharpness adjustment. Options: Auto, 0~15

Flip-H: Image flipped horizontally. Options: On, Off.

Flip-V: Image flips vertically. Options: On, Off

B&W-Mode: Image color. Options: On, Off

Gamma: Options: Default, 0.45, 0.5, 0.56, 0.63

Style: Options: Norm, Clarity, Bright, Soft, 5S.

adjustment. Options: On, Off

AF-Zone: Focusing area of interest. Options: Top, Center, Bottom

AF-Sense: Automatic focusing sensitivity. Options: Low, Normal, High

L/R Set: Options: STD, REV

Display Info: Options: On, Off

Image Freeze: Options: On, Off

Digital Zoom: Options: Off, 2x,4x,8x,16x

Call Preset Speed: Options:1~24

5. P/T/Z

P/T/Z		
▶ SpeedByZoom		On
AF-Zone		Center
AF-Sense		High
L/R Set		STD
Display Info		On
Image Freeze		Off
Digital Zoom		Off
Call Preset Speed		24
▲▼ Select Item		
◀▶ Change Value		
[Menu] Back		

6. NOISE REDUCTION

Move the cursor to Noise Reduction in the main menu and press [HOME]. NOISE REDUCTION menu shows as below.

NOISE REDUCTION		
▶ NR2D-Level		3
NR3D-Level		3
D-HotPixel		Off
▲▼ Select Item		
◀▶ Change Value		
[Menu] Back		

NR2D-Level: 2D noise reduction. Options:

SpeedByZoom: The depth of field scale Off, Auto, 1 ~ 5

NR3D-Level: 3D noise reduction. Options: the HDMI output.

Off, 1 ~ 8

Video Format: Options: 1080P60,1080P50,

D-HotPixel: Dynamic bad points. Options: 720P60,720P50,1080P30,1080P25,720P30,720P2

Off, 1 ~ 5

5

7. SETUP

Move the cursor to Setup in the main menu and press [HOME]. SETUP menu shows as below.

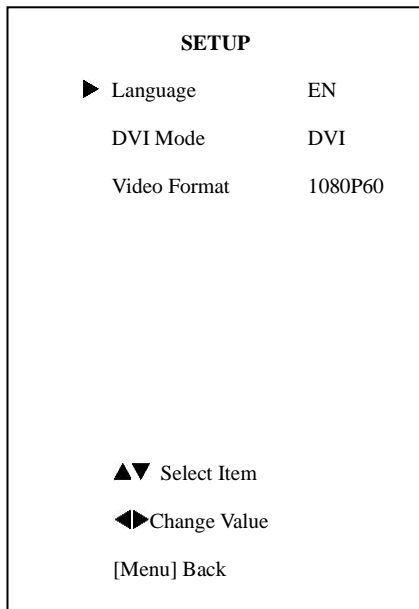

Language: Menu language. Options: English, Chinese, Russian

DVI Mode: Options: DVI, HDMI



Note:

When switch the camera from DVI mode to HDMI mode, user needs to save the change and restart camera. There will be embedded audio in

8. COMMUNICATION SETUP

Move the cursor to Setup in the main menu and press [HOME]. COMMUNICATION SETUP menu shows as below.

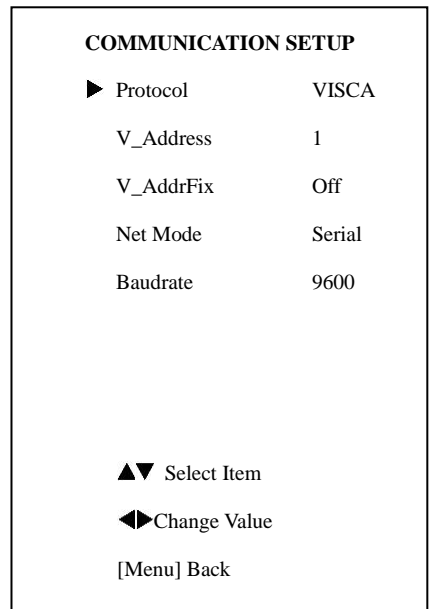

Protocol: Control protocol type. Options: AUTO, VISCA, PELCO-D, PELCO-P

V_Address: Protocol address, consistent with the agreement. Options: AUTO, VISCA.

P_D_Address: PELCO-D protocol. Options:

0 ~ 254

P_P_Address: PELCO-P protocol. Options: 0

~ 31

V_AddrFix: Change serial port using infrared switch. Options: On, Off (when set to On, command 88 30 01 FF becomes invalid)

Net Mode: Set the serial port control pattern.
Options: Serial, Paral

Baudrate: Serial port baud rate. Options:
2400, 4800, 9600,38400

9. RESTORE DEFAULT

Move the cursor to Restore Default in the main menu and press [HOME], RESTORE DEFAULT menu shows as below.

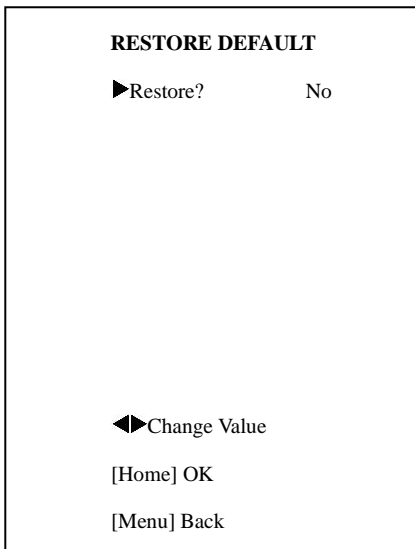

Restore: Restore factory settings. Options:
Yes, No

Note: Press [HOME] to confirm. All parameters will be reset to default values, including IR Remote address and VISCA address.

Save: Save settings. Options: Yes, No

Network Function

1 Operating Environment

Operating System: Windows 2000/2003/XP/
vista/7/8/10

Network Protocol: TCP/IP.

Client PC: P4/128MRAM/40GHD/ supports
scaled graphics card, DirectX8.0 or more
advanced version.

2 Equipment Installation

1) Connect internet camera to a wireless
network (Wi-Fi) or to your PC directly via internet
cable.

2) Turn on DC12V power.

3) When the orange light on internet port lit
up, green light flashing, the physical connection is
finished.

3 Internet Connection

There are 2 ways of connecting internet
camera to computer.

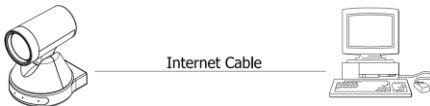

Connect by internet cable

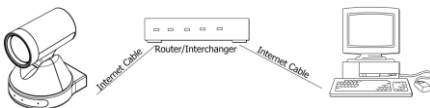

Connect by router /interchanger

4 IP camera visited/ controlled by LAN

4.1 Setup IP address

IP camera's default IP address is 192.168.
100.88. For unknown camera IP, follow the
instructions to reveal:

Method 1: press * and # and 4 on remote
control in order, the camera IP address will show
on screen.

Method 2: connect camera to PC with
Ethernet cable, use "upgrade_En.exe" to search
for IP address.



To change IP address, follow the steps:

Method 1: On web control page, click
"Network" > change IP > click "Apply" > restart
camera

A screenshot of the camera's web control interface. The "LAN Settings" section is active, showing "IP Configuration Type" set to "Fixed IP Address". The IP Address is 192.168.100.131, Subnet Mask is 255.255.255.0, Gateway is 192.168.100.1, and DNS Address is 8.8.8.8. The MAC Address is D4 ED 8E 48 A1 C2. Below this are "Port Settings" (HTTP Port number: 80, RTSP Port: 554, PTZ Port: 5678) and "Control Protocol Settings" (Visca Address: 1, Pelco-D Address: 0, Pelco-P Address: 0). There are also sections for "RTMP Settings", "RTSP Settings", "ONVIF Settings", "Multicast Settings", and "SDK Settings". Each section has "Apply" and "Cancel" buttons.

Method 2: Open "upgrade_En.exe", change
IP and click "Set". After modifying, restart IP

Camera.

UPGRADE v1.9

Search Upgrade Config Backup

Mode: Manual

IP Address: 192.168.100.88

Mask: 255.255.255.0

Gateway: 192.168.100.1

First DNS: 192.168.100.1

MAC Address: D4 : E0 : 8E : DB : 18 : 08

Set Reset

Language: English



NOTE!

IP camera's default IP address: "192.168.100.88", user: "admin", password: "admin".

4.2 Visit/Access IP Camera

Input <http://192.168.100.88> in the address bar (better with IE web browser, others will cause a little latency). When login window pops up, input login name: admin, password: admin.

Windows Security

The server 192.168.100.88 is asking for your user name and password. The server reports that it is from ..

Warning: Your user name and password will be sent using basic authentication on a connection that isn't secure.

User name

Password

Remember my credentials

OK Cancel

After login, the page will be as below:



NOTE!

If the camera is used for the first time with Internet connection, user must install a video player (VLC). Please go to VLC website <http://www.videolan.org/vlc/download> and install as instructed. After installation, login again, the home page will show.

5 IP Camera accessed/controlled by WAN (Internet)

5.1 Setup IPC accessed/controlled by dynamic DNS

2 dynamic DNS available:

Dyndns.org,

3322.org

Router Port Mapping:

Take Tenda router for example, enter Router Home Page (interface page)> select "Advanced"> "Virtual Server"> add a new port number in "Ext Port"> add a new port number in "Int port"> put camera IP address as "Internal IP"> "Save".

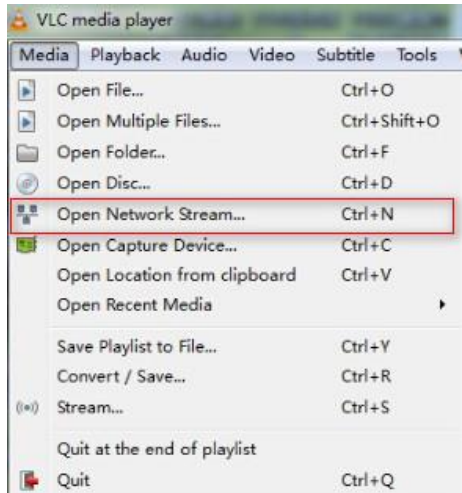
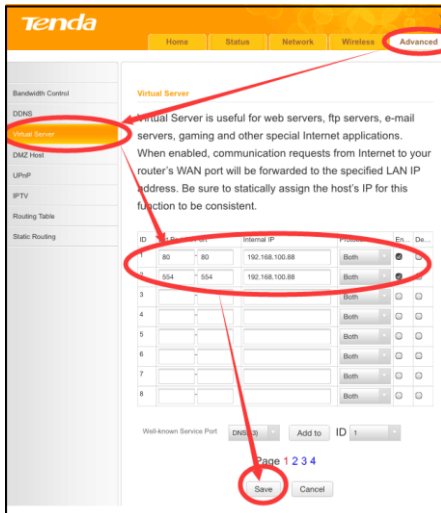

Input URL address:

rtsp://ip: port number/1 (First stream);

rtsp://ip: port number/2 (Second stream).



NOTE!

Default port number: 554.

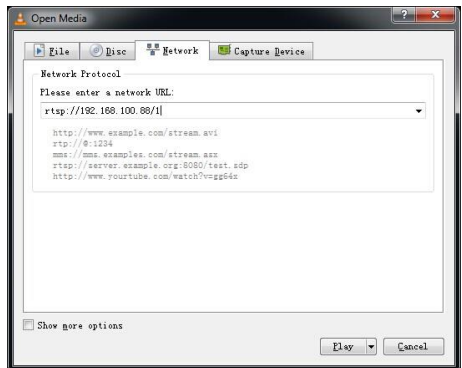

5.2 Dynamic DNS visits camera

Set domain name to camera, set the parameter, and then dynamic DNS can access camera. Access link: <http://hostname: port number>.

For example, if set host computer name:

youdomain.f3322.org, camera port number: 554,

then the access link should be:

<http://youdomain.3322.org:554>.



NOTE!

If the default camera port is 80, it's unnecessary to enter port number. By using only the host name, user can access camera directly.

5.3 VLC stream media player monitoring

Visit VLC media server procedure

Open VLC media player, click "Media"> "Open Network Steam", or use "Ctrl+N".

6 IP Camera parameter setup

6.1 Homepage introduction

Menu

All pages include 2 menu bars:

Real-time monitoring: display video.

Parameter setup: function buttons.

A. Video viewing window

Video viewing window must accommodate to the video resolution: the higher the resolution is, the bigger the playing area should be. Double clicking viewing window will show full-screen; double clicking again will return to initialized size.

Status bar in viewing window shows as below:



1) Video playback pause button: control real-time video pause, stop at the last frame. Click again to resume video.

2) Audio control buttons: can set silent mode.

3) Full screen switch button.

B. PTZ Setup

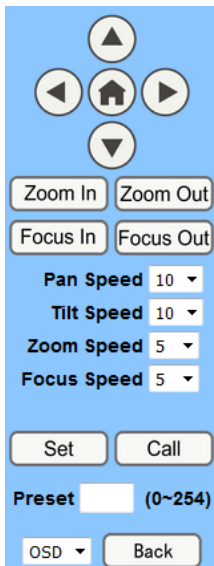

1) PTZ direction control box: up, down, left, right, home oblique button.

2) Rate: Vertical speed can be set to any value from 1 ~ 24, horizontal direction can be set to any rate between 1 ~ 20.

3) Select a certain speed and click the direction button to realize PTZ speed up or speed down.

4) Zoom In/ Zoom out: for zooming in or zooming out. Focus In/ Focus Out: Focusing on distant objects or on close objects.

5) Set/ Call: when PTZ turns to expected position, it can be saved as a preset entry as below.

Method 1: Type a number into the Preset box.



Method 2: Type a name into the Preset information.

Presets Information		
No.	Name	
1	<input type="text"/>	Set
2	<input type="text"/>	Set
3	<input type="text"/>	Set
4	<input type="text"/>	Set
5	<input type="text"/>	Set
6	<input type="text"/>	Set
7	<input type="text"/>	Set
8	<input type="text"/>	Set
9	<input type="text"/>	Set

Then click "Set" button. When PTZ turns to other positions, click "Call" button or click "No." of the Presets Information, PTZ will redirect to

the corresponding preset position.



6) MENU/ PTZ:

MENU: system in menu mode. OSD menu displays at the upper corner of the image page.

PTZ direction control box: up/down button selects menu; home button enters the submenu, left/right button modifies the submenu. After the menu being modified, select PTZ. If in the main menu, system will save the settings and exit automatically. Otherwise, return to the previous menu. "Back" button effective only in submenu.

PTZ: system in PTZ mode.

PTZ: system in PTZ mode.

PTZ: system in PTZ mode.

C. Language selection

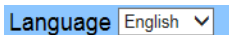

Chinese/English/Russian

6.2 Click "Video" to finish video setup:

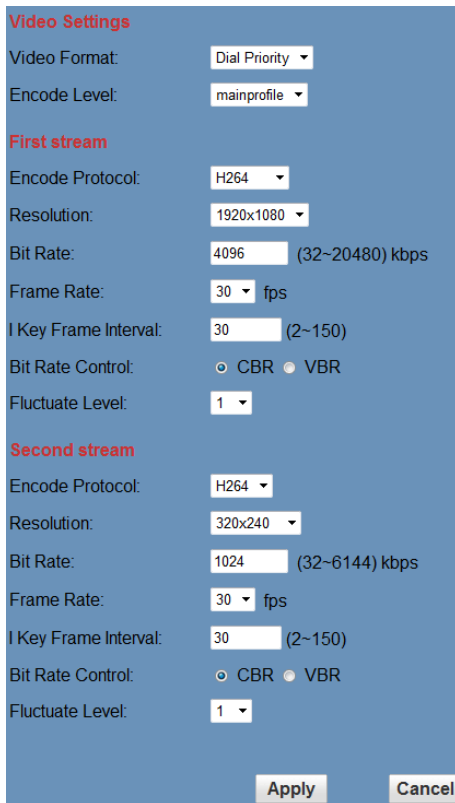

1) Video format

Support 3 formats: 50Hz (PAL), 60Hz (NTSC), and Dial priority.

2) Encode Level

Support 3 formats: baseline, mainprofile, and highprofile.

3) Encode Protocol

Support 3 formats: H.264, H.265, and MJPEG.

4) Resolution

First bit flow supports 1920x1080, 1280x720, 1024x576, 960x540, 640x480 and 640x360.

Second bit flow supports 1280x720, 1024x576, 720x576(Under 50Hz), 720x480(Under 60Hz), 720x408, 640x360, 480x270, 320x240 and 320x180. The higher the resolution is, the clearer the image will be, and more network bandwidth will be taken.

5) Bit Rate

User can assign bit flow/stream. Normally a larger bit flow contributes to a clearer image. The bit allocation must coordinate network bandwidth. When the network bandwidth is narrow while the allocated bit flow is too large, the video signal flow will not be transmitted normally, and the video quality will thus be corrupted.

6) Frame rate

User can specify a proper frame rate. Generally, a higher frame rate gives a smoother image. With a smaller frame rate, there is a higher chance of beating.

7) I key frame interval:

Set interval between 2 I frames, the bigger the interval is, the slower the response will be in the viewing window.

8) Bit Rate (code stream) control

Constant bit rate: video coder will be coding according to the preset speed.

Variable bit rate: video coder will adjust the speed based on preset speed for the best image quality.

9) Fluctuate level

Restrain the fluctuation magnitude within grade 1 ~ 6.



NOTE!

To adjust the parameters, click "apply" to save, click "cancel" to discard the change of the parameters.

6.3 Click "Image" to finish image setup:



1) Brightness

Brightness 0~14, slide to control. The box on the right shows the corresponding numerical. Default: 7.

2) Saturation

Saturation 0~14, slide to control. The box on the right shows the corresponding numerical. Default: 4.

3) Contrast

Contrast 0~14, slide to control. The box on the right shows the corresponding numerical. Default: 7.

4) Sharpness

Sharpness 0~15, slide to control. The box on the right shows the corresponding numerical. Default: 2.

5) Hue

Hue 0~14, slide to control. The box on the right shows the corresponding numerical. Default: 7.

6) Flip & Mirror

Click “Flip” to flip image upside down. Click “mirror” to show the mirror image.



NOTE!

To adjust the parameters, click "apply" to save, click "cancel" to discard the change of the parameters, click "default" to restore the default values.

6.4 Click “Audio” to finish audio setup:

The screenshot shows the 'Audio Settings' menu with the following options:

- Audio Type: AAC
- Sample Rate: 48K
- Bit Rate: 96K
- Input Type: Line in
- Input Vol L: 8 (-97~30) db
- Input Vol R: 8 (-97~30) db
- ADTS Options: Off

Buttons: Apply, Cancel

1) Audio Type

Audio type: AAC.

2) Sample rate

Sample rate: 44.1 K and 48 K.

3) Bit rate

Bit rate: 96k, 128k, 256k.

4) Input Type

Line-in only.

5) Input Vol L

Volume of the left channel.

6) Input Vol R

Volume of the right channel

7) ADTS Options

Options: On, Off



NOTE!

Click "apply" to save parameter settings. Click "cancel" to discard changes.

6.5 Click “System” to change system settings:

The screenshot shows the 'System' menu with the following options:

- Work Mode: RTSP
- Reboot: Reboot
- User: admin
- Passwd: *****

Buttons: Apply, Cancel

Other visible options: Live, Video, Image, Audio, System, Network, Information, Zoom In, Zoom Out, Focus In, Focus Out, Pan Speed, Tilt Speed, Zoom Speed, Focus Speed, Set, Call, Preset, PTZ, Back, Language: English

1) Work Mode

Work mode: RTSP

2) Reboot

Click "Reboot", system restarts.

3) User and password

User can modify the user name and password (letters and numbers only).



NOTE!

Click "apply" to finish password setting and go back to the login page. Click "cancel" to discard the change.

6.6 Click "Network" to finish network setup:

The screenshot shows a web-based configuration interface for a network camera. The left sidebar contains navigation options: Live, Video, Image, Audio, System, Network (highlighted), and Information. The main content area is titled 'User Settings' and is divided into several sections: 'User Settings' (IP Configuration Type, IP Address, Subnet Mask, Gateway, DNS Address, MAC Address), 'Port Settings' (HTTP, RTSP, PTZ), 'Control Protocol Settings' (Visca, Pelco-D, Pelco-P), 'RTSP Settings' (First stream, Second stream), 'RTSP Settings' (Auth, ONVIF, ONVIF Auth), 'Multicast Settings' (Address, Port), and 'SDK Settings' (Active Connection, Address, Port). Each section contains input fields and radio buttons for configuration. At the bottom of each section are 'Apply' and 'Cancel' buttons. The language is set to English.

1) Lan Settings

Default IP address: 192.168.100.88. MAC address can be modified.



NOTE!

To adjust the Lan parameters, click "apply" to save, click "cancel" to discard the change of the parameters.

2) Port Settings

A. HTTP Port

IP address identifies the network device. Each device can run multiple web applications which use network port to transmit data. Data transmission is to be carried out between ports, and the port setup is to assign WEB SERVER program the corresponding port. The port mapping needs to be consistent with the port number (default port: 80).

B. RTSP Port

Network camera supports RTSP protocol, and user can use the VLC tools to broadcast.

C. PTZ Port

Support PTZ protocol, default port: 5678.

3) Control Protocol Setting

Set camera-control communication protocols, including Visca address, Pelco-D address, and Pelco-P address.

4) RTMP Setting

Set up to two camera streams. For each, select control of "On", "Off", "Video", "Audio", etc.

5) RTSP Setting

Set network camera RTSP protocol, choose "On"/"Off".

6) ONVIF Setting

Set ONVIF protocol and authorization, choose "On"/"Off".

7) Multicast Setting

Set multicast, choose "On"/"Off". Set multicast address (default: 224.1.2.3) and port (default: 6688).

8) SDK Setting

Set SDK, choose "On"/"Off". Set multicast

address (default: 192.168.1.138) and port (default: 1234).



NOTE!

Modify network parameters then click "Apply". Click "Cancel" to discard parameter changes.

6.7 Click “Information” to finish device information setup:

A screenshot of a software dialog box titled "Information" in red text. It contains four rows of labels and text boxes: "Device ID:" with "HD Camera", "Software Version:" with "SOC v7.2.10 - ARM v6.2.53T", "Device Type:" with "F1.V", and "Webware Version:" with "v1.4.4". At the bottom right are two buttons: "Apply" and "Cancel".

Device ID:	HD Camera
Software Version:	SOC v7.2.10 - ARM v6.2.53T
Device Type:	F1.V
Webware Version:	v1.4.4

Note:

Software version may not be the latest one, the released version shall prevail.

7 Download the upgrade program

If the camera upgrade program is needed, please contact the manufacturer.

Maintenance and Troubleshooting

Camera Maintenance

- If camera will be idle for a long time, please turn off the power switch, disconnect AC power cord from the outlet.
- Use soft cloth or tissue to clean the camera (lens not recommended).
- Use the soft dry cloth to clean the lens. If the camera is very dirty, clean it with diluted neuter detergent. Do not use any type of solvents, which may damage the surface.

Unqualified Application

- No being exposed to light of extremely high intensity or for a long period of time, such as sunlight, special light sources, etc.
- No operating under unstable lighting conditions, otherwise image will be flickering.
- No operating close to powerful electromagnetic radiation, such as TV or radio transmitters, etc.

Troubleshooting

Image

- No image
 1. Check if the power cord is connected, or voltage is right, or POWER light is on.
 2. Check if the camera can self-test upon start-up.
 3. Check if video cable is connected correctly.

- Abnormal display of image

Check if video cable is connected correctly.

- Image dithering even at widest zoom position

1. Check if camera is set correctly.
2. Make sure there is no vibration machine or other disturbing devices nearby.

- No video/ image in IE browser

When IPC is for the first time accessed by Internet Explorer (or other web browser), a plug-in must be installed.

Installation: visit IP Camera address, click [Download], and a download dialog box will pop up. Select [Run] or [Save] to download. If no dialog box pops up, please go to VLC (player software) website <http://www.videolan.org/vlc/download> and install VLC. After download completed, install as instructed. After successfully installed, login again, and the video/ image will show.

-
- Unable to access IP Camera by IE browser.

1. Access network with PC, check if network works. In this way, user can get rid of any cable failure or network failure.
2. Disconnect IP Camera from network. Connect IP Camera to PC, and re-set the IP address following the proper operations.
3. Check the server's IP address, subnet mask and gateway address.
4. Check if MAC addresses conflict.
5. Check if web port is occupied by other devices.

- When modify IP address incorrectly (cause the wrong IP address), or forget the web password, press "[*]+[#]+[Manual]" on the IR remote control to restore the default settings (Default IP: 192.168.100.88; Default username: admin; Default password: admin)

Sound

- No sound
 1. Check the audio connection to the host PC.
 2. Check IP Camera audio parameter settings, and check if intercepting function is on.

Control

- IR remote control cannot control the camera
 1. Change the battery
 2. Check if the camera is in working mode.
- Serial communication cannot control the camera
 1. Check if the camera is in working mode.
 2. Check if the control cable is connected correctly.